

**Features**

- 1-channel signal conditioner
- Universal usage at different power supplies
- Input for 2- or 3-wire sensors, NAMUR sensors or dry contacts
- Input frequency 1 mHz ... 10 kHz
- Current output 0/4 mA ... 20 mA
- Relay contact and transistor output
- Start-up override
- Line fault detection (LFD)
- Up to SIL 2 acc. to IEC 61508/IEC 61511

**Function**

This signal conditioner provides the isolation for non-intrinsically safe applications.

The device is a universal frequency converter that changes a digital input signal into a proportional free adjustable 0/4 mA ... 20 mA analog output signal and functions as a switch amplifier and a trip alarm.

The functions of the switch outputs (2 relay outputs and 1 potential free transistor output) are easily adjustable [trip value display (min/max alarm), serially switched output, pulse divider output, error signal output].

The device is easily configured by the use of keypad or with the PACTware configuration software.

A fault is signaled by LEDs acc. to NAMUR NE44.

n, refer to the manual and

**Assembly**

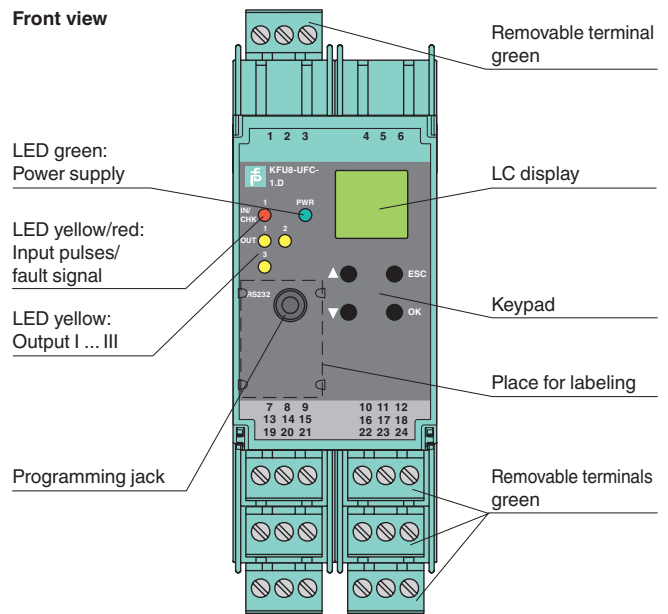

**SIL 2**

**Connection**

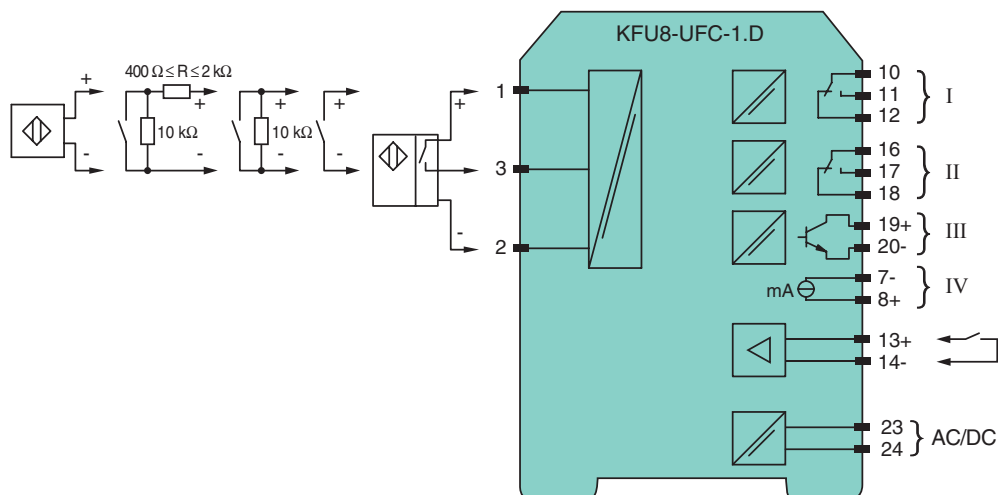

Release date 2018-09-13 10:08 Date of issue 2018-09-13 231195\_eng.xml

|                                             |                                                                                                                                       |
|---------------------------------------------|---------------------------------------------------------------------------------------------------------------------------------------|
| <b>General specifications</b>               |                                                                                                                                       |
| Signal type                                 | Digital Input                                                                                                                         |
| <b>Functional safety related parameters</b> |                                                                                                                                       |
| Safety Integrity Level (SIL)                | SIL 2                                                                                                                                 |
| <b>Supply</b>                               |                                                                                                                                       |
| Connection                                  | terminals 23, 24                                                                                                                      |
| Rated voltage $U_r$                         | 20 ... 90 V DC / 48 ... 253 V AC 50 ... 60 Hz                                                                                         |
| Power dissipation/power consumption         | $\leq 2 \text{ W}$ ; 2.5 VA / 2.2 W ; 3 VA                                                                                            |
| <b>Interface</b>                            |                                                                                                                                       |
| Programming interface                       | programming socket                                                                                                                    |
| <b>Input</b>                                |                                                                                                                                       |
| Connection side                             | field side                                                                                                                            |
| Connection                                  | Input I: 2-wire sensor: terminals 1+, 3- three wire sensor: terminals 1+, 2- and 3<br>input II: terminals 13+, 14- start-up override; |
| Input I                                     | 2- or 3-wire sensor, sensor acc. to EN 60947-5-6 (NAMUR) or mechanical contact                                                        |
| Open circuit voltage/short-circuit current  | 22 V / 40 mA                                                                                                                          |
| Input resistance                            | 4.7 k $\Omega$                                                                                                                        |
| Switching point/switching hysteresis        | logic 1: $> 2.5 \text{ mA}$ ; logic 0: $< 1.9 \text{ mA}$                                                                             |
| Pulse duration                              | $> 50 \mu\text{s}$                                                                                                                    |
| Input frequency                             | 0.001 ... 10000 Hz                                                                                                                    |
| Line fault detection                        | breakage $I \leq 0.15 \text{ mA}$ ; short-circuit $I > 4 \text{ mA}$                                                                  |
| Input II                                    | startup override: 1 ... 1000 s, adjustable in steps of 1 s                                                                            |
| Active/Passive                              | $I > 4 \text{ mA}$ (for min. 100 ms) / $I < 1.5 \text{ mA}$                                                                           |
| Open circuit voltage/short-circuit current  | 18 V / 5 mA                                                                                                                           |
| <b>Output</b>                               |                                                                                                                                       |
| Connection side                             | control side                                                                                                                          |
| Connection                                  | output I: terminals 10, 11, 12<br>output II: terminals 16, 17, 18<br>output III: terminals 19+, 20-<br>output IV: terminals 8+, 7-    |
| Output I, II                                | signal, relay                                                                                                                         |
| Contact loading                             | 250 V AC / 2 A / $\cos \phi \geq 0.7$ ; 40 V DC / 2 A                                                                                 |
| Mechanical life                             | $5 \times 10^7$ switching cycles                                                                                                      |
| Energized/De-energized delay                | approx. 20 ms / approx. 20 ms                                                                                                         |
| Output III                                  | electronic output, passive                                                                                                            |
| Contact loading                             | 40 V DC                                                                                                                               |
| Signal level                                | 1-signal: (L+) -2.5 V (50 mA, short-circuit/overload proof)<br>0-signal: blocked output (off-state current $\leq 10 \mu\text{A}$ )    |
| Output IV                                   | analog                                                                                                                                |
| Current range                               | 0 ... 20 mA or 4 ... 20 mA                                                                                                            |
| Open loop voltage                           | $\leq 24 \text{ V DC}$                                                                                                                |
| Load                                        | $\leq 650 \Omega$                                                                                                                     |
| Fault signal                                | downscale $I \leq 3.6 \text{ mA}$ , upscale $\geq 21.5 \text{ mA}$ (acc. NAMUR NE43)                                                  |
| <b>Transfer characteristics</b>             |                                                                                                                                       |
| Input I                                     |                                                                                                                                       |
| Measurement range                           | 0.001 ... 10000 Hz                                                                                                                    |
| Resolution                                  | 0.1 % of the measurement value , $\geq 0.001 \text{ Hz}$                                                                              |
| Accuracy                                    | 0.1 % of the measurement value , $> 0.001 \text{ Hz}$                                                                                 |
| Measuring time                              | $< 100 \text{ ms}$                                                                                                                    |
| Influence of ambient temperature            | 0.003 %/K (30 ppm)                                                                                                                    |
| Output I, II                                |                                                                                                                                       |
| Response delay                              | $\leq 200 \text{ ms}$                                                                                                                 |
| Output IV                                   |                                                                                                                                       |
| Resolution                                  | $< 10 \mu\text{A}$                                                                                                                    |
| Accuracy                                    | $< 20 \mu\text{A}$                                                                                                                    |
| Influence of ambient temperature            | 0.005 %/K (50 ppm)                                                                                                                    |
| <b>Galvanic isolation</b>                   |                                                                                                                                       |
| Input I/other circuits                      | reinforced insulation according to IEC/EN 61010-1, rated insulation voltage 300 V <sub>eff</sub>                                      |
| Output I, II/other circuits                 | reinforced insulation according to IEC/EN 61010-1, rated insulation voltage 300 V <sub>eff</sub>                                      |
| Mutual output I, II, III                    | reinforced insulation according to IEC/EN 61010-1, rated insulation voltage 300 V <sub>eff</sub>                                      |
| Output III/power supply                     | reinforced insulation according to IEC/EN 61010-1, rated insulation voltage 300 V <sub>eff</sub>                                      |
| Output III/IV                               | basic insulation according to IEC/EN 61010-1, rated insulation voltage 50 V <sub>eff</sub>                                            |
| Output IV/power supply                      | reinforced insulation according to IEC/EN 61010-1, rated insulation voltage 300 V <sub>eff</sub>                                      |
| Start-up override/power supply              | reinforced insulation according to IEC/EN 61010-1, rated insulation voltage 300 V <sub>eff</sub>                                      |

Release date 2018-09-13 10:08 Date of issue 2018-09-13 231195\_eng.xml

|                                  |                                                                                                                              |
|----------------------------------|------------------------------------------------------------------------------------------------------------------------------|
| Interface/power supply           | reinforced insulation according to IEC/EN 61010-1, rated insulation voltage 300 V <sub>eff</sub>                             |
| Interface/output III             | basic insulation according to IEC/EN 61010-1, rated insulation voltage 50 V <sub>eff</sub>                                   |
| <b>Indicators/settings</b>       |                                                                                                                              |
| Display elements                 | LEDs , display                                                                                                               |
| Control elements                 | Control panel                                                                                                                |
| Configuration                    | via operating buttons<br>via PACTware                                                                                        |
| Labeling                         | space for labeling at the front                                                                                              |
| <b>Directive conformity</b>      |                                                                                                                              |
| Electromagnetic compatibility    |                                                                                                                              |
| Directive 2014/30/EU             | EN 61326-1:2013 (industrial locations)                                                                                       |
| Low voltage                      |                                                                                                                              |
| Directive 2014/35/EU             | EN 61010-1:2010                                                                                                              |
| <b>Conformity</b>                |                                                                                                                              |
| Electromagnetic compatibility    | NE 21:2006                                                                                                                   |
| Degree of protection             | IEC 60529:2001                                                                                                               |
| <b>Ambient conditions</b>        |                                                                                                                              |
| Ambient temperature              | -20 ... 60 °C (-4 ... 140 °F)                                                                                                |
| <b>Mechanical specifications</b> |                                                                                                                              |
| Degree of protection             | IP20                                                                                                                         |
| Connection                       | screw terminals                                                                                                              |
| Mass                             | 300 g                                                                                                                        |
| Dimensions                       | 40 x 119 x 115 mm (1.6 x 4.7 x 4.5 inch) , housing type C3                                                                   |
| Mounting                         | on 35 mm DIN mounting rail acc. to EN 60715:2001                                                                             |
| <b>General information</b>       |                                                                                                                              |
| Supplementary information        | Observe the certificates, declarations of conformity, instruction manuals, and manuals where applicable. For information see |
| <b>Accessories</b>               |                                                                                                                              |
| Optional accessories             | - FDT framework PACTware 4.1<br>- device type manager DTM Interface Technology<br>- adapter K-ADP-USB                        |

### Maximum Switching Power of Output Contacts

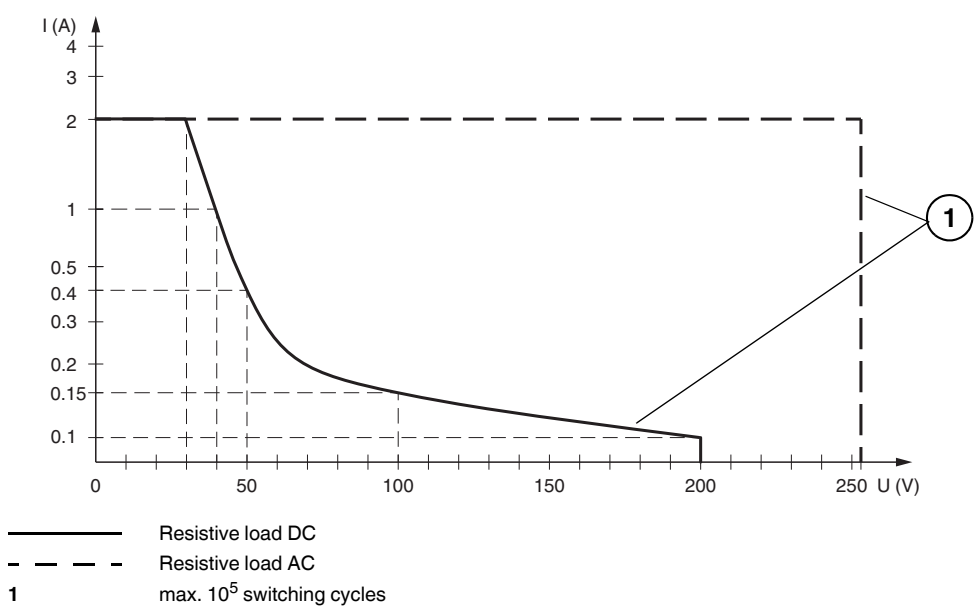

Release date 2018-09-13 10:08 Date of issue 2018-09-13 231195\_eng.xml